

Valve Controller T1 User Manual

Product Introduction

Aqara Valve Controller T1 is a valve controller based on Zigbee wireless communication protocol, which is suitable for wireless control and manual control of valves in pipelines. It can be linked with water leak/gas sensors and other devices to realize risk identification, notification and treatment to protect home property and personal safety.

* This device needs to be used with Aqara Home app and an Aqara Zigbee Hub, hereinafter referred to as App and the Hub, Aqara Valve Controller T1, hereinafter referred to as the device.

* For more Aqara product details, please visit www.aqara.com

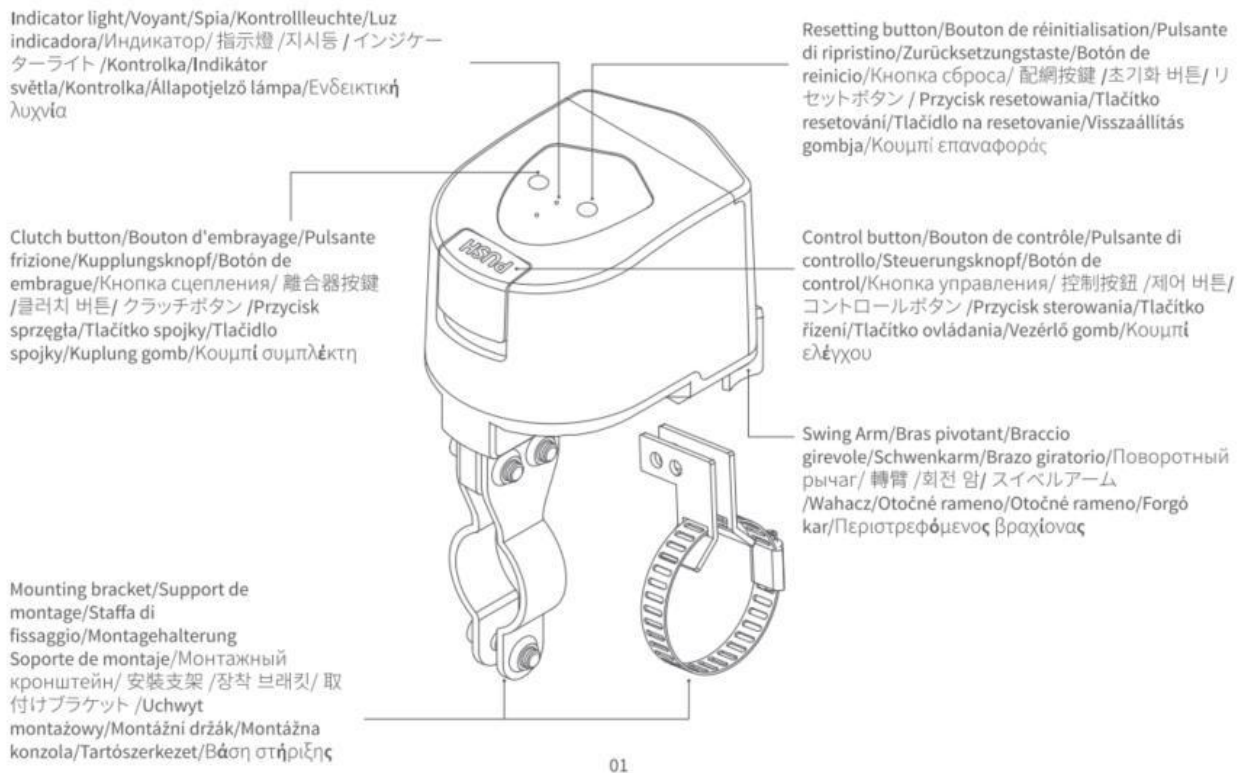

Product Installation

4, 6 points pipe diameter

1. Find the valve piping where you plan to install the equipment, manually switch the valve once to make sure that the valve is in a state

where it can be normally switched on and off, and please adjust the valve to open.

Note:

①At least 187 * 248 mm size should be reserved above the pipeline to ensure that there is enough space to install the equipment.

②Before connecting the device, ensure the mechanical arm's 0-90 degree travel range is clear of foreign objects or interference to prevent equipment damage during commissioning.

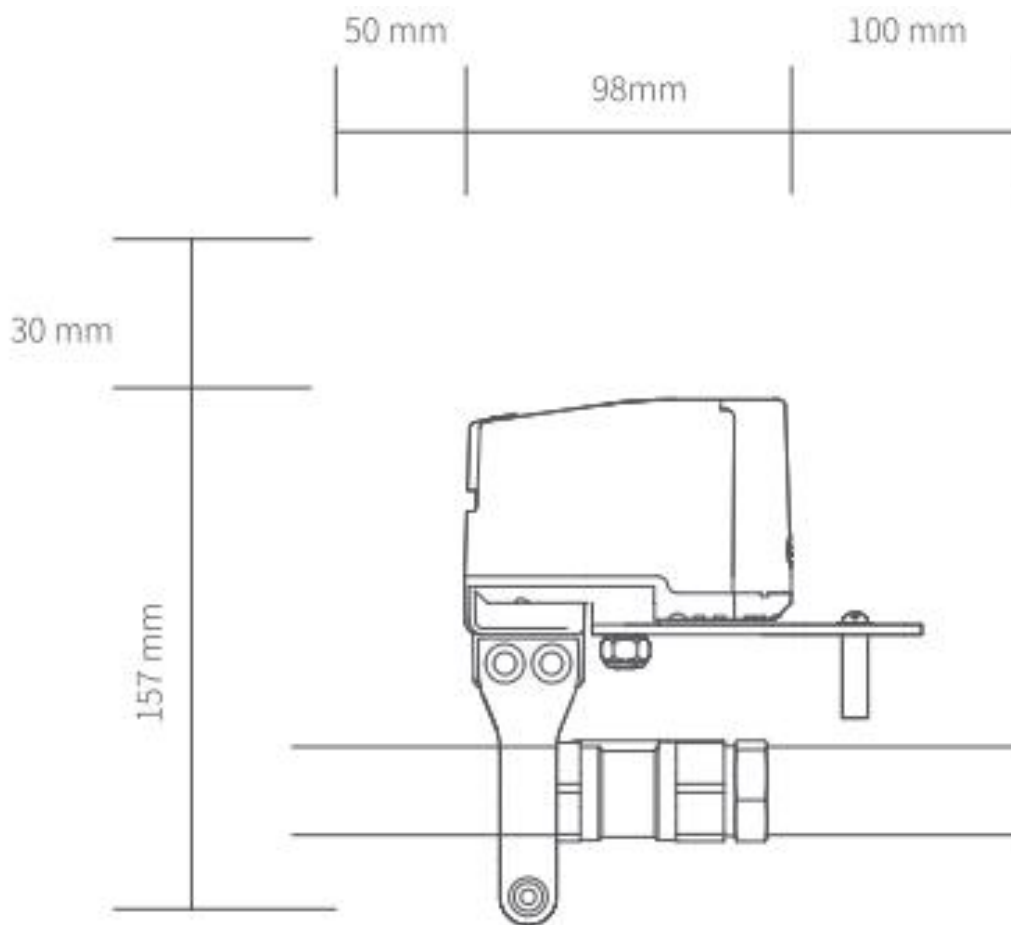

2. Pre-mount the 2 pieces of mounting bracket on the pipe using screws (do not tighten the screws yet).

Note: The mounting bracket is suitable for pipes up to a maximum DN20 size. If there is a large gap between the mounting bracket and the pipe during installation, please insert the rubber gasket on the outer side of the pipe before securing it with the mounting bracket.

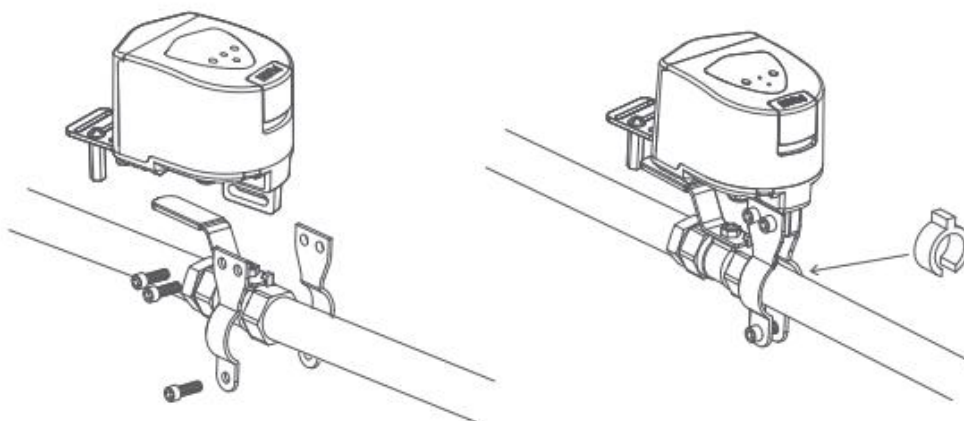

3. Move the device to the valve, secure the swivel arm to the valve handle, and take note of the mounting position of the controller, ensuring that the output shaft of the unit aligns with the center axis of the valve swivel.

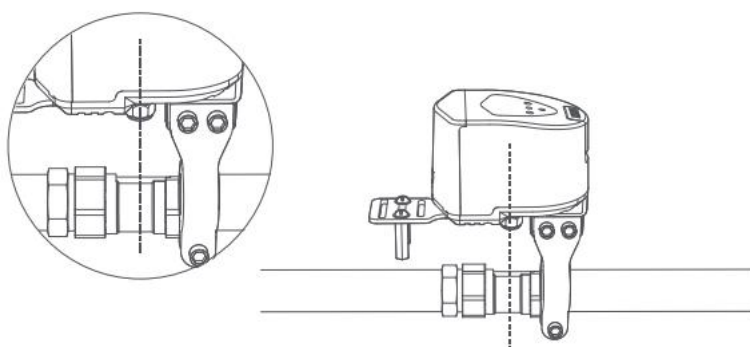

4. Tighten the mounting bracket screws to ensure the stability of the device.

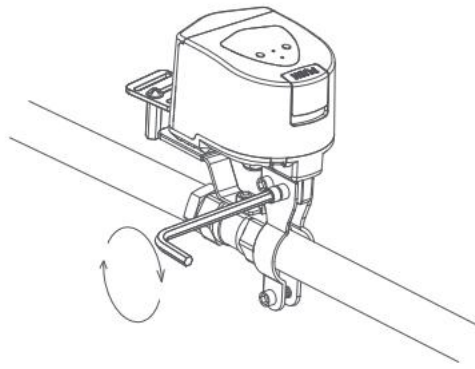

5. Open the battery compartment, install the batteries, and then re-close the battery compartment.

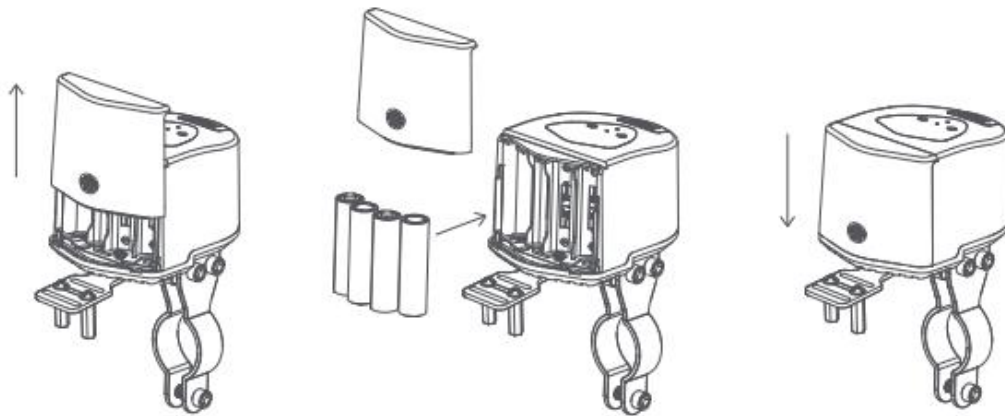

6. Click the work button, the device will perform a closing action. If the equipment

wobbles or breaks away from the valve handle during the working process, please re-fix it. The installation is complete when you make sure that the device remains stable in the working condition.

Note: When adjusting the stability of the device, please remove the battery to prevent accidentally touching the device during the adjustment process, resulting in the operation of the device and causing inconvenience.

For DN25 pipes

1. Locate the valve piping where you intend to install the equipment, manually open and close the valve once to verify that it operates correctly, and then adjust the valve to the open position.

Note:

① At least 187 * 248 mm size should be reserved above the pipeline to ensure that there is enough space to install the equipment.

② Before connecting the device, ensure the mechanical arm's 0-90 degree travel range is clear of foreign objects or interference to prevent equipment damage during commissioning.

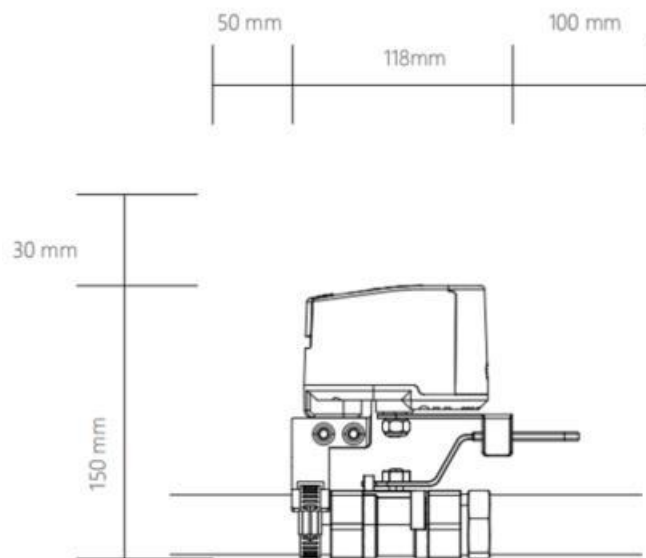

2. Attach the 2-piece mounting bracket to the device by screws.

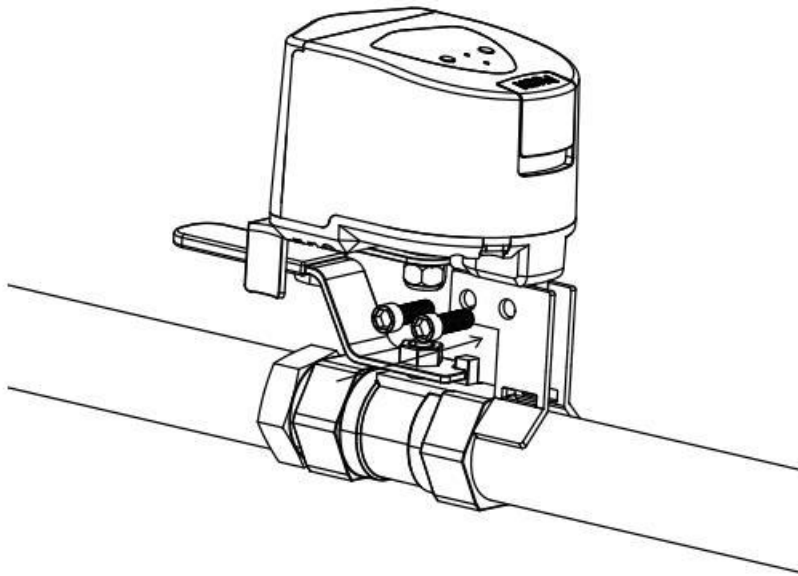

3. Adjust the pipe fixture, turn the screw to loosen the fixture, and thread the fixture through the hole under the bracket to finish installing the bracket and fixture.

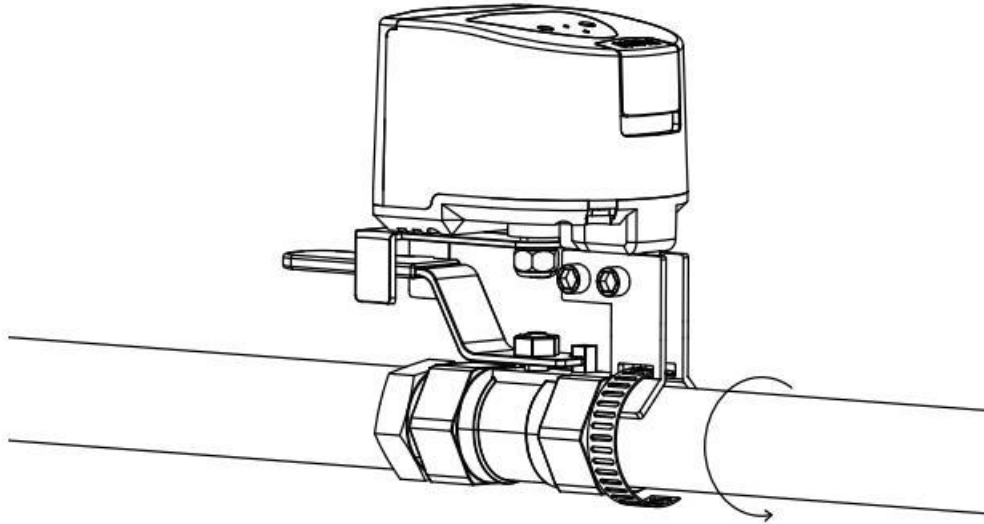

4. Move the device to the valve, attach the swivel arm to the valve handle, and carefully observe the installation position of the device, ensuring that the output axis of the device aligns with the center axis of the valve swivel.

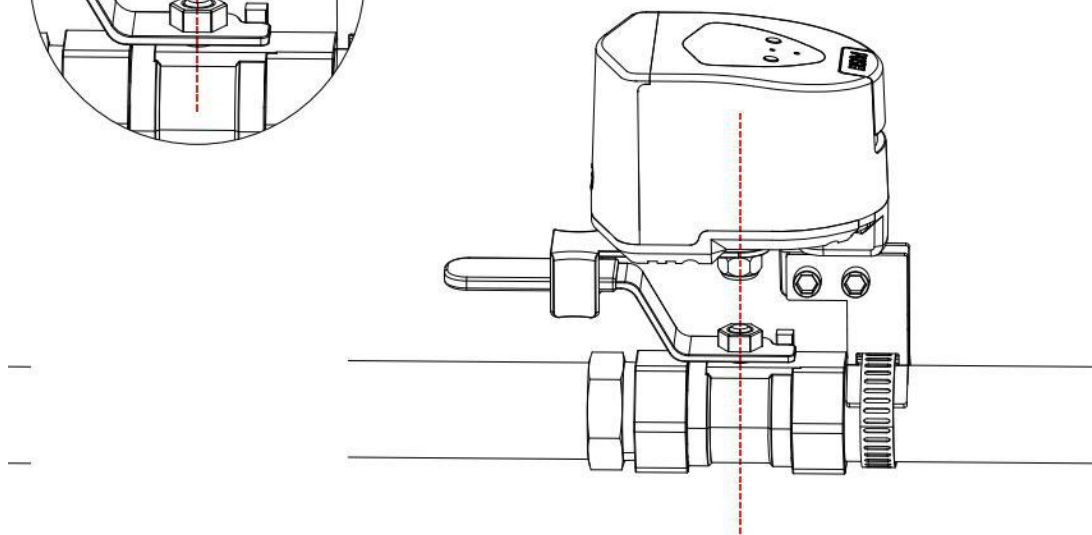
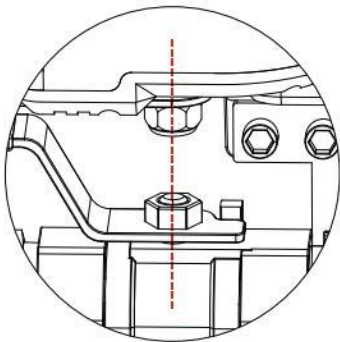

5. Tighten the mounting screws to secure the pipe clamps around the pipe and ensure the equipment's stability.

Note: If there is a significant gap between the bracket and the pipe during installation, insert the rubber washer on the outer side of the pipe before securing the pipe with the pipe clamp.

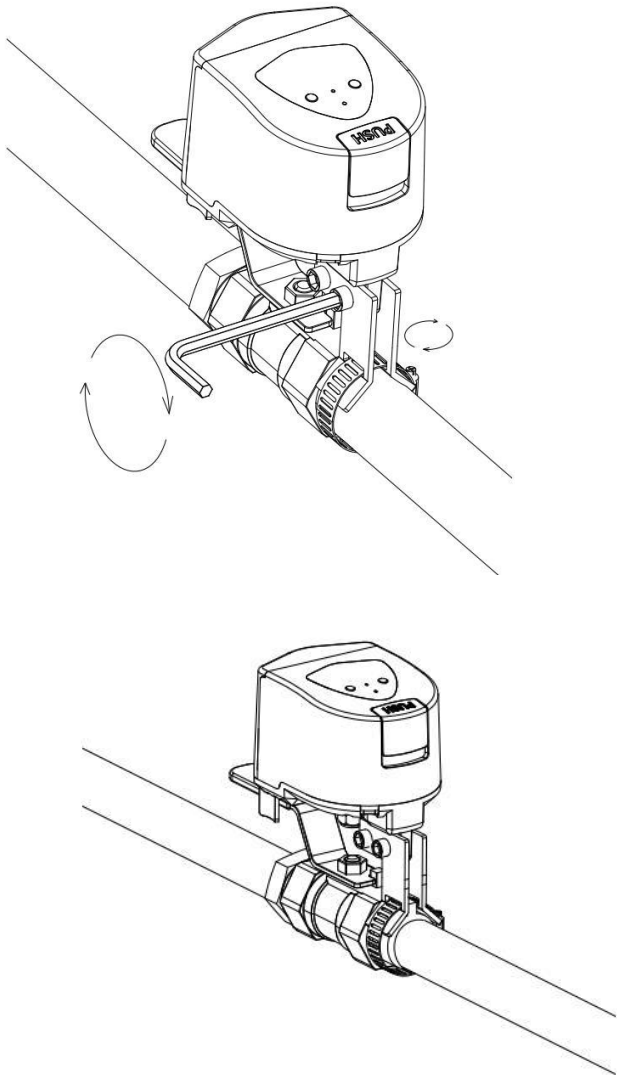

6. Open the battery compartment, install the batteries, and then close the battery compartment again.

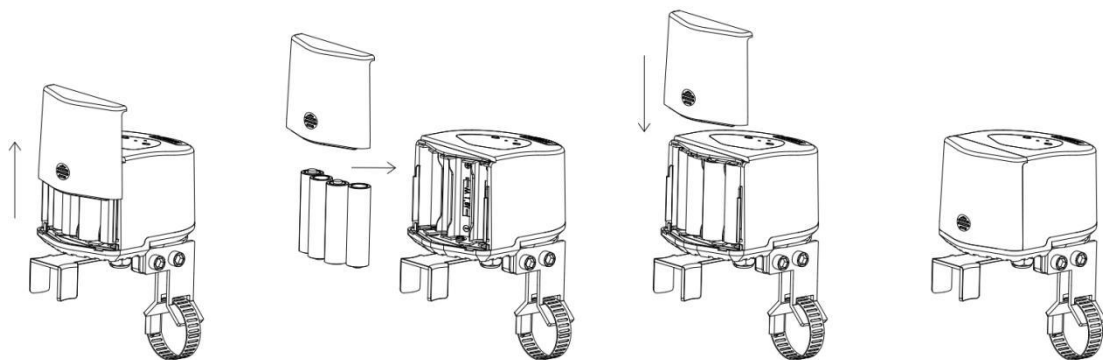

7. Click the work button, the device will perform a closing action. If the device wobbles or breaks away from the valve handle during the working process, please

re-fix it. The installation is complete when you make sure that the device remains stable in the working condition.

Note: When adjusting the stability of the device, please remove the battery to prevent accidentally touching the device during the adjustment process, resulting in the operation of the device and causing inconvenience.

Butterfly Valve Type Installation

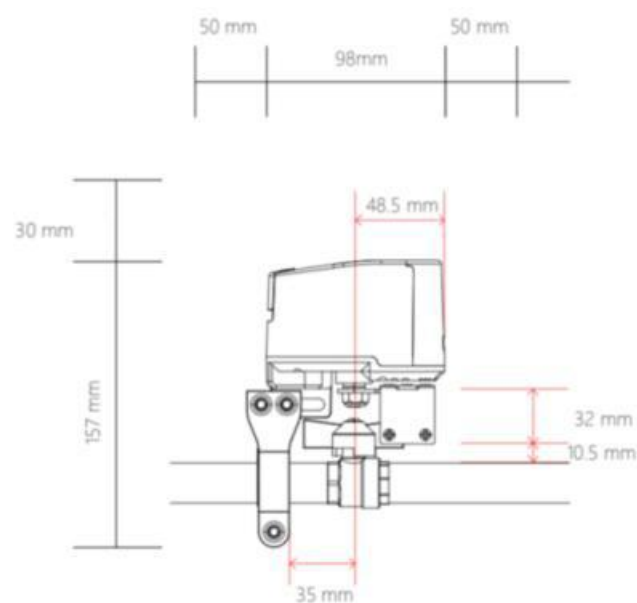

1. Find the valve piping where you plan to install the equipment, manually switch the valve once to ensure it can be normally turned on and off, and then adjust the valve to the open position.

Note:

① At least 187 * 248 mm size should be reserved above the pipeline to ensure that there is enough space to install the equipment.

② Before connecting the device, ensure the mechanical arm's 0-90 degree travel range is clear of foreign objects or interference to prevent equipment damage during commissioning.

2. Open the butterfly handle valve accessory package and assemble the fixture. Secure the swing arm and the clamp with three screws, while pre-installing the other two screws in the holes below the clamp.

* Ensure the smooth side of the arm faces upwards; position the holes on the underside of the clamp towards the inside of the arm.

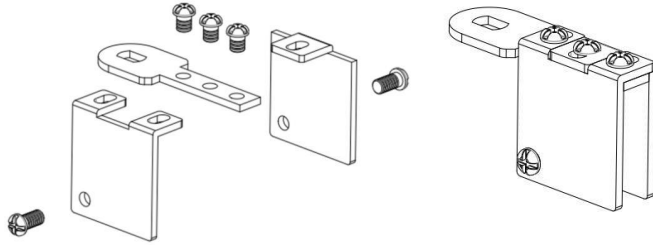

3. Use an Allen key or pliers to rotate counterclockwise, loosen the hex nut located below the device, and disassemble the nut, washer, and the swing arm for lever handles.

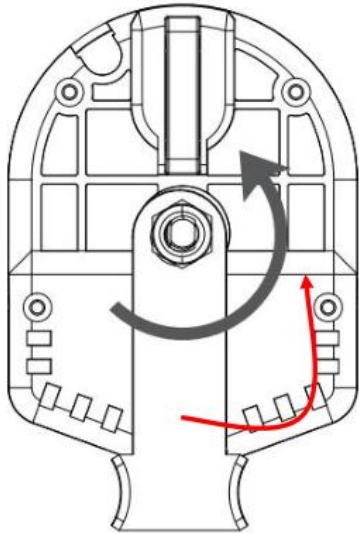

4. Install the butterfly handle swing arm onto the device in the following order: nut from the accessory package, swing arm, and then the securing nut.

Note: when installing, do not tighten the nut to the point of locking it. Once installation is complete, operate the device once to check if the device is functioning properly.

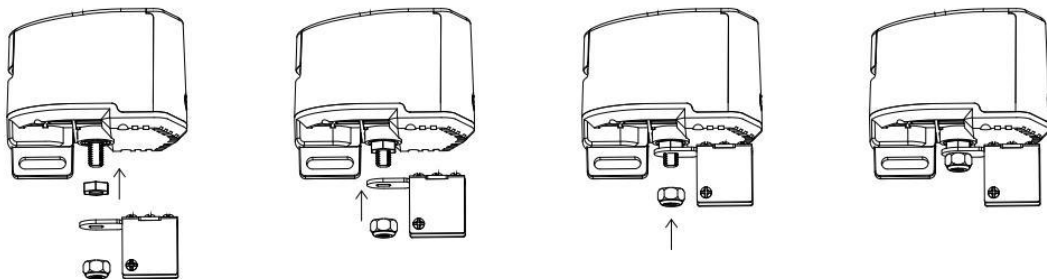

5. Move the device onto the valve, secure the arm with the valve handle, and pay attention to the installation position of the device. Ensure that the axis of the swing arm aligns with the valve handle's.

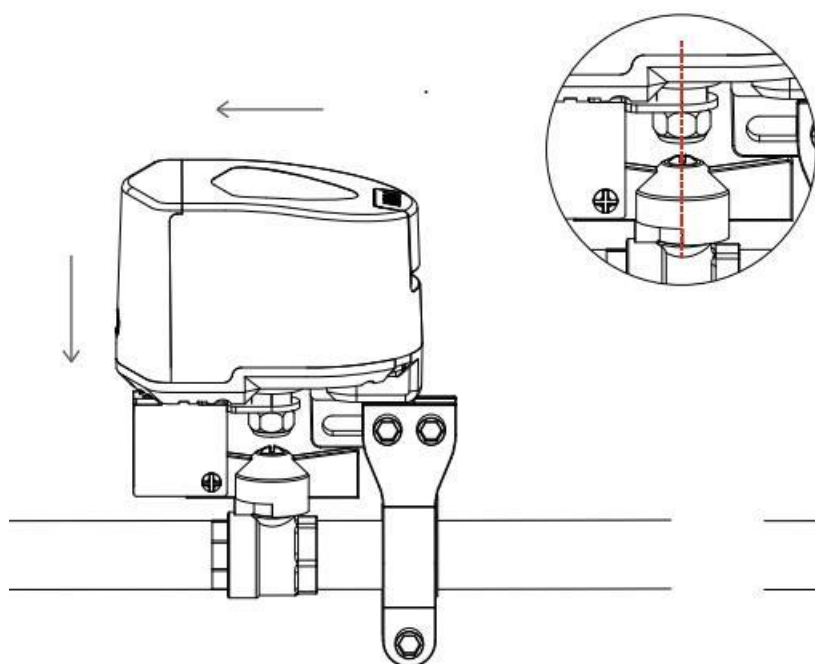

* The picture showcases installation onto DN15/20 pipes.

6. Tighten the mounting bracket screws to ensure the stability of the equipment.

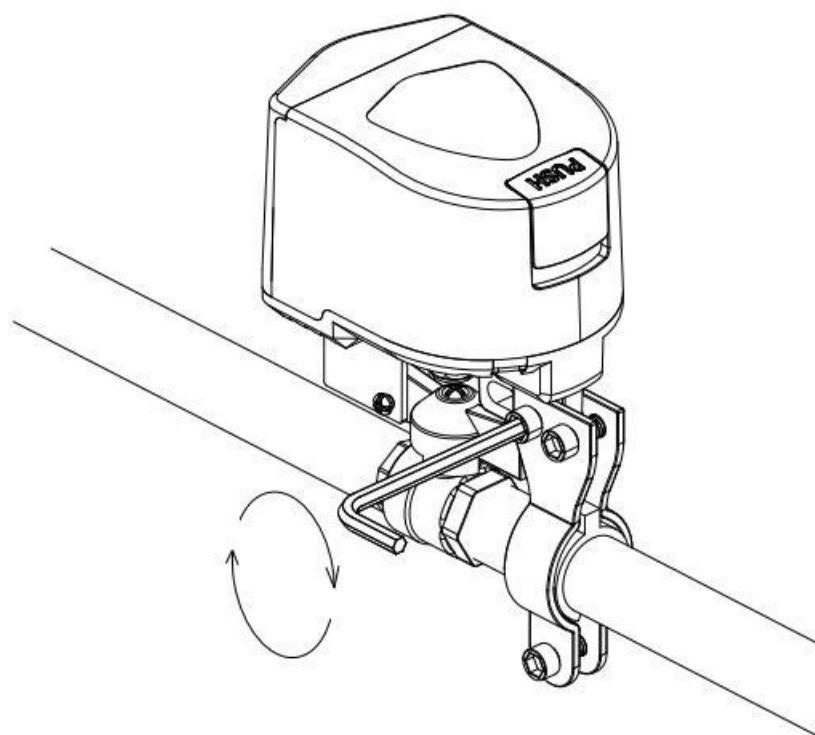

7. According to the style of the butterfly handle, adjust the screws of the clamp to ensure that the fixture can secure the butterfly handle without any interference during operation.

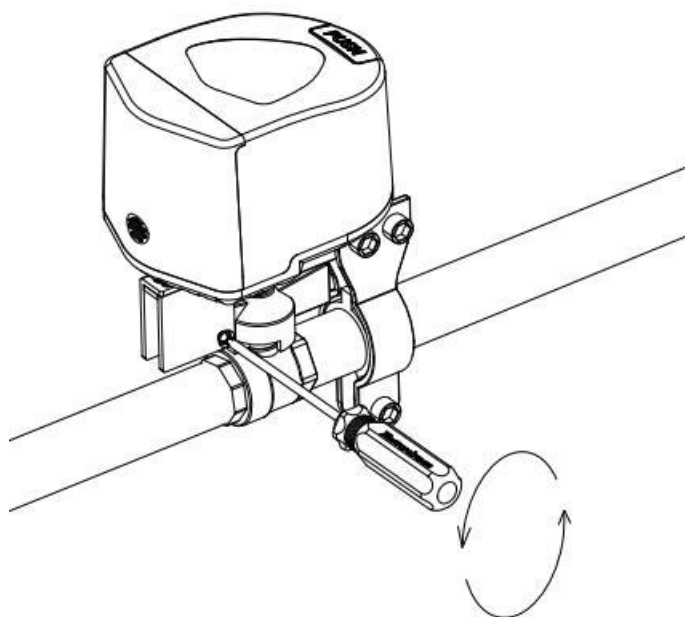

8. Open the battery compartment, install the batteries, and then close the battery compartment again.

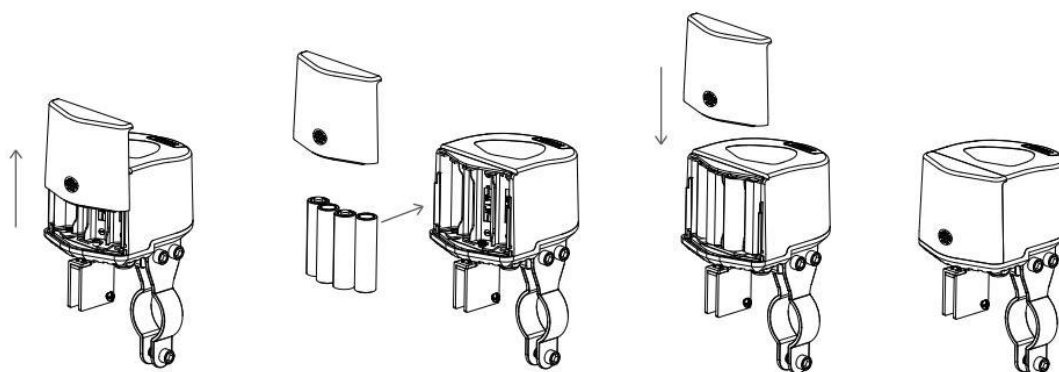

9. Click the Controller button once, and the equipment will perform a closing action. If the equipment shakes or detaches from the valve handle during operation, please re-secure it. Once you ensure that the equipment remains stable during operation, the installation is complete. Note: When adjusting the stability of the equipment, remove the batteries to prevent accidental operation during the adjustment process, causing inconvenience.

Quick Setup

1. Please download the latest version of Aqara Home App via the app store or scan the QR code below.



Aqara Home APP

2. Please make sure the hub is bound in the Aqara Home account you are using. If you have not bound the hub, please refer to the manual of the hub to add the hub to the app.

3. Open the app, click "+" in the upper right corner of the home page, enter the page of adding equipment (accessories), select "Valve Controller T1", and follow the prompts to operate; you can also scan the device body by clicking Scan Logo in the upper right corner of the home page on the upper right corner of the home page, scan the QR code of the device body to add equipment.

* If adding fails, please move the product closer to the hub, re-power on and try again. 3. Control the device through App, if the device status changes, it means the device is connected normally.

* Valid distance verification: Click the distribution button 3 times consecutively, and the hub emits a beep, it means that the device and the hub can communicate with each other effectively (only Aqara Home app supports this function).

* To ensure the user experience, please update the device firmware to the latest version after the device has finished binding and then use it.

Operating Guidelines

Key Control

When the device is powered on, press the "Control" button on the

device to initiate the open/close action. The status indicator will flash green while the device is in operation.

Manual Control

Press the clutch "PUSH" button and manually rotate the arm, then release the clutch "PUSH" button after the arm has finished rotating.

Note: The clutch "PUSH" button may not be able to spring back to reset after it is released, please shake the arm gently, and when you hear the "click" sound, the clutch "PUSH" button will finish springing back. Please shake the arm gently.

Buttons & Indicators & Device Status

Device status	Indicator status	Buzzer Status
Ready to bound to hub	Green device status light blinks fast	/
Connecting to hub	Green device status light blinks slowly 1 time	/
Device during operation of on/off	Green device status light blinks slowly until the end of the	/
Communication function verification	Green device status light blinks 3 times slowly	/
Abnormal in alarm state	Green device status light blinks 1 time	Synchronized buzzer sound
Device is offline or not on the network	Red indicator blinks fast for 10S	/
Device failure	The red indicator blinks every 10S (1S on) for 30S.	Synchronized buzzer sound
Low battery	The red indicator flashes every 30S (1S	

Action on Button(s)	Indicator Status	Device Status
Click on Reset	Green indicator light flashing fast	Alarm status release
Click on Reset 3 times quickly	Green indicator light flashing fast	Communication distance verification
Click on Reset 5 times quickly	Green indicator light flashing fast	Device reset

Device Alarm

Reasons

1. Equipment timeout: equipment switching valve maximum working time 20S, if

more than 20S is not completed, the equipment alarm

2. Equipment is not completely open/close: equipment work is completed, the valve does not reach 0/90 °, that is, not completely open/close, the equipment alarm Processing Procedure

1. Click the distribution network button to clear the alarm.

2. Press the "PUSH" button on the clutch, manually rotate the arm to reset the device, and release the "PUSH" button after resetting.

3. Check the valve status to ensure that rust or any issues do not prevent the

equipment from fully controlling the valve. If there is an issue, please repair the valve promptly.

Product Specifications

Product size: 93 × 72 × 84 mm (3.66 × 2.83 × 3.31 in.) Wireless connection: Zigbee

Power supply: AA Battery × 4

Valve pressure: 1.6MPa

Torque: ≤3.6 N·m

Operating temperature: -10°C- 50°C

Working humidity: 0-95%, non-condensing

Valve opening/closing time: 5-20s

Compatible Pipe Sizes: DN15, DN20, DN25

Compatible Handle Types: lever handle, butterfly handle

Warnings

1. This product is for indoor use only, please do not use it outdoors;

2. Pay attention to moisture, please do not spill water or other liquids on this product; 3. Do not place the product near a heat source;

4. Do not allow children to play with the controller, place the device away from children;

5. This product is only intended to enhance the entertainment and convenience of your family life and for device status reminders, and the

manufacturer is not responsible for any risk or property damage caused by any violation of the product's instructions for use and these precautions by the user.

6. Please do not attempt to repair this product yourself, this work should be carried out by an authorized professional.

7. This product is intended for safe use only at altitudes up to 2000 meters above sea level.

* Please read these instructions carefully and keep them in a safe place

Manufacturer: Lumi United Technology Co., Ltd.

Address: Room 801-804, Building 1, Chongwen Park, Nanshan iPark, No. 3370, Liuxian Avenue, Fuguang Community, Taoyuan Residential District, Nanshan District, Shenzhen, China.

Online Customer Service:

www.aqara.com/support Email:

support@aqara.com