

Operational Instruction

Apply to: Reolink Altas PT Ultra

Contents

What's in the Box	2
Device Overview	3
Camera States	3
Set up the Camera	4
Charge the Camera	6
Install the Camera	7
Troubleshooting	11
Specifications	11
Important Safety Instructions (For Battery-Powered Cameras)	11
Legal Disclaimer	13
Notification of Compliance	14

What's in the Box



Device

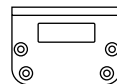

Mounting Bracket



Strap



USB-C Cable



Surveillance Sign

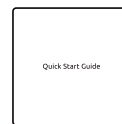

Quick Start Guide



Mounting Hole Template

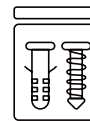

Pack of Screws

Device Overview

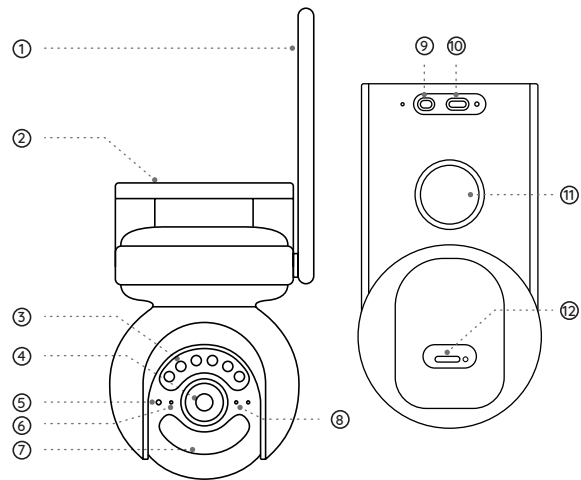

- ① Antenna
- ② Ceiling mounting bracket
- ③ White light
- ④ Lens
- ⑤ Daylight Sensor
- ⑥ Indicator light
- ⑦ PIR lens
- ⑧ Microphone hole
- ⑨ Power button
- ⑩ Type-C interface
*Support USB-A to USB-C cable only
- ⑪ Speaker hole
- ⑫ Micro SD card slot

Camera States

Power & Reset Button Instructions:

Power on: Press and hold for 2s

Power off: Press and hold for 5s

Reset to factory settings: Press the button 3 times in a row when the camera is on

Set up the Camera

Set up the Camera Using a Smartphone

Step 1 Scan to download the Reolink App from the App Store or Google Play store.



Step 2 Press and hold the power switch for two seconds to power on the camera.

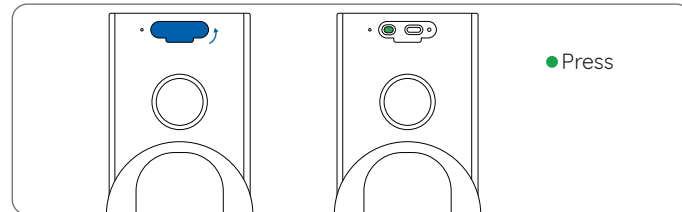

Step 3 Launch the Reolink App, click the “+” button in the top right corner to add the camera. Scan the QR code on the device and follow the onscreen instructions to finish initial setup.

NOTE: This product has two QR codes, one on the back of the machine and one on the bottom of the machine. When you have installed the machine, if you need to configure the device again, you can scan the QR code on the bottom of the device.

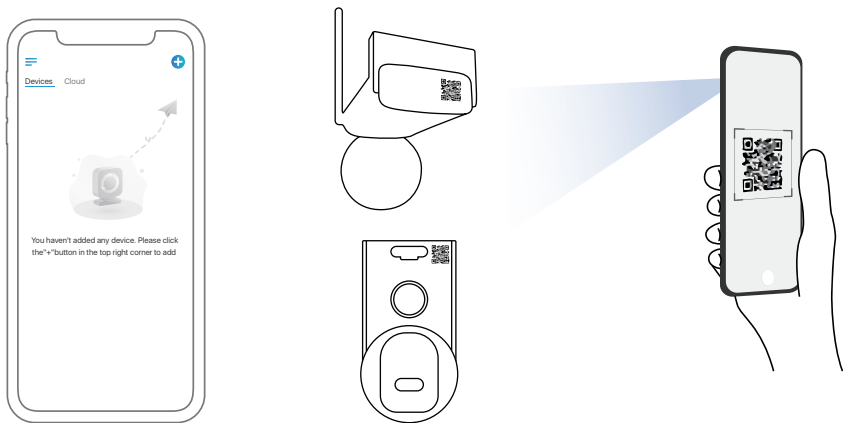

Step 4 In the “Add Device” page, configure the Wi-Fi connection by enabling Bluetooth on your phone and follow the onscreen instructions to finish the initial setup.

Charge the Camera

It's recommended to fully charge the camera before installing it.

Charging Indicator:

- Orange LED: Charging
- Green LED: Fully charged

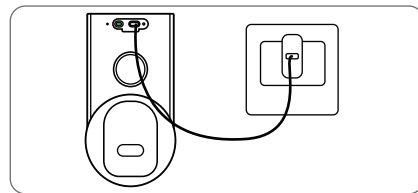

Charge the camera with a 5V power adapter (not included).

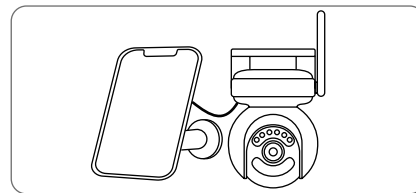

Charge the camera with the Reolink Solar Panel (not included if you only purchase the camera). For details about the installation of Reolink Solar Panel, see its Operational Instruction.

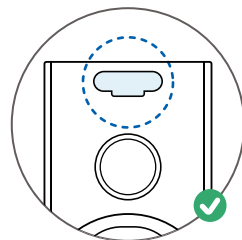

For better weatherproof performance, please always cover the charging port with the rubber plug after charging the camera.

Install the Camera

Install the camera in residential areas with faint ambient lighting at night or wild areas with moonlight or starlight, so it can deliver true full-color night vision. Even in extreme darkness with no light source, the camera will turn on its spotlights for extra lighting.

- Install the camera 2-3 meters (7-10 ft) above the ground. This height maximizes the detection range of the PIR motion sensor.

- For better motion detection performance, please install the camera angularly.

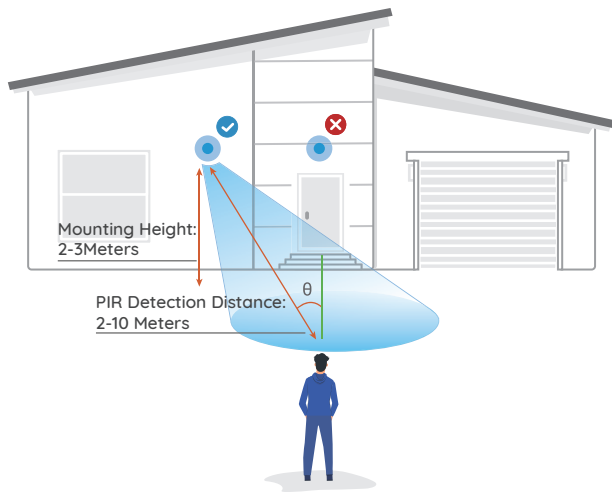

NOTE: Make sure the side-to-side movement crosses the camera's field of view. If a moving object approaches the PIR sensor vertically, the camera may fail to detect motion.

Ceiling or Wall Mounting Camera

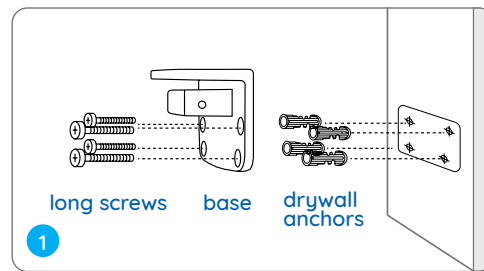

Wall Mounting Camera

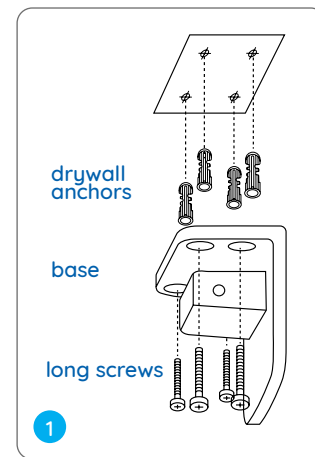

Ceiling Mounting Camera

Drill holes according to the installation template. Drive 4 long screws into the drill holes. If it is a hard wall, please drive the wall anchor into the drill hole first, and then tighten the long screws.

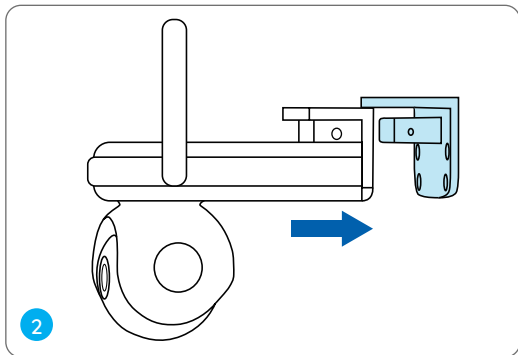

Install the camera onto the mounting base.

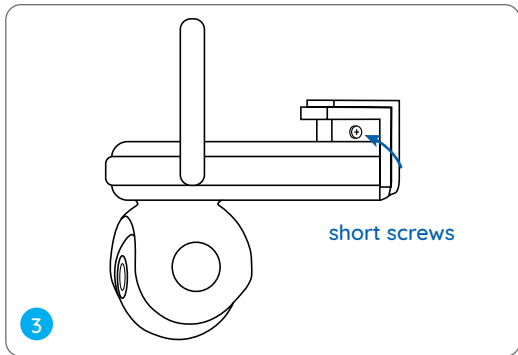

To secure the camera, drill the two short screws into the corresponding holes on the mounting base and the side of the camera.

Camera Mounting Strap

Thread the provided straps onto the board and secure it to the tree as shown below.

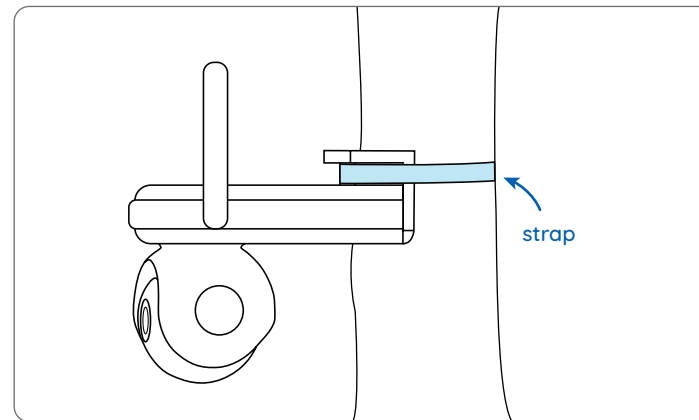

Troubleshooting

Camera is not Powering on

If your camera is not powering on, please apply the following solutions:

- Make sure the power switch is turned on.
- Charge the battery with a DC 5V/2A power adapter. When the green light is on, the battery is fully charged.

If these won't work, please contact Reolink Support <https://support.reolink.com/>.

Failed to Scan the QR Code on the Phone

If the camera cannot scan the QR code on your phone, please try the following solutions:

- Remove the protective film from the camera lens.
- Wipe the camera lens with a dry paper/towel/tissue.
- Vary the distance between your camera and the mobile phone so that the camera can focus better.

- Try to scan the QR code under sufficient lighting.

If these won't work, please contact Reolink Support <https://support.reolink.com/>.

Specifications

Operating Temperature: -10°C to 55°C (14°F to 131°F)
Size: 151*178*102mm
Weight: 853g

For more specifications, visit the Reolink official website.
Please visit <https://reolink.com/>.

Important Safety Instructions (For Battery-Powered Cameras)

Please read the instructions carefully before using the camera. For tips on extending battery life, visit our support post: <https://support.reolink.com/hc/en-us/articles/360006991893>

1. Charge the battery with a standard and high-quality DC 5V battery charger or Reolink solar panel. It is not compatible with solar panels from any other brands.

2. Replace only with the same or equivalent type of equipment and accessories recommended by the manufacturer. Using an incorrect type poses an explosion risk.

3. Do not remove a built-in battery from the camera.

4. Charge the battery only in temperatures between 0°C and 45°C . And use it only in temperatures ranging from -10°C and 55°C .

5. Do not charge, use or store a battery camera near heat sources, such as space heaters, cooking surfaces, cooking appliances, irons, radiators, or fireplaces. Extreme heat may cause an explosion.

6. Do not expose the camera with a battery to extremely low air pressure environments, as this may cause an explosion.

7. Do not place the camera with a battery in hot wilderness areas or expose it to lightning, as this poses a risk of fire.

8. Do not hit or heavily compress the camera

with a battery, as this poses a risk of fire or explosion.

9. Do not use the battery if it appears damaged, swollen, or compromised in any way (e.g., leaking, emitting odors, dented, corroded, rusted, cracked, swollen, melted, or scratched).

10. Keep the camera and battery away from children.

11. Do not ingest or swallow battery. If the battery is ingested or swallowed, it can cause severe internal burns and damage. Seek immediate medical attention if you suspect the battery has been ingested or placed inside any part of the body.

12. Do not attempt to disassemble, repair, or alter the camera or battery by yourself.

13. Keep the charging port dry, clean and free of any debris. Cover it with the rubber plug after the battery is fully charged.

14. Always follow the local safety laws and regulations when using the camera.

15. Always follow the local waste and recycling laws to dispose of used batteries.

Legal Disclaimer

To the maximum extent permitted by applicable law, this document and the product described, with its hardware, software, firmware, and services, are delivered on an “as-is” and “as-available” basis, with all faults and without warranty of any kind. Reolink disclaims all warranties, express or implied, including but not limited to, warranties of merchantability, satisfactory quality, fitness for a particular purpose, accuracy, and non-infringement of third-party rights. In no event will Reolink, its directors, officers, employees, or agents be liable to you for any special, consequential, incidental or indirect damages, including but not limited to damages for loss of business profits, business interruption, or loss of data or documentation, in connection with the use of this product, even if Reolink has been advised of the possibility of such damages. To the extent permitted by applicable law, your use of the Reolink products and services is at your sole risk and you assume all risks associated with internet access. Reolink does not take any responsibilities for abnormal operation, privacy leakage or other damages resulting from cyber attacks, hacker attacks, virus inspections, or other internet security risks. However, Reolink will provide timely technical support if required.

The laws and regulations related to this product vary by jurisdiction. Please check all relevant laws and regulations in your jurisdiction before using this product to ensure that your use conforms to the applicable law and regulation. During the use of the product, you must comply with relevant local laws and regulations. Reolink is not responsible for any illegal or improper use and its consequences. Reolink is not liable in the event that this product is used with illegitimate purposes, such as third-party rights infringement, medical treatment, safety equipment, or other situations where the product failure could lead to death or personal injury, or for weapons of mass destruction, chemical and biological weapons, nuclear explosion, and any unsafe nuclear energy uses or anti-humanity purposes. In the event of any conflicts between this manual and the applicable law, the latter prevails.

Notification of Compliance

FCC Statement

This device complies with Part 15 of the FCC Rules. Operation is subject to the following two conditions:

- (1) This device may not cause harmful interference, and
- (2) This device must accept any interference received, including interference that may cause undesired operation. Changes or modifications not expressly approved by the party responsible for compliance could void the user's authority to operate the equipment. This equipment has been tested and found to comply with the limits for a Class B digital device, pursuant to Part 15 of the FCC Rules. These limits are designed to provide reasonable protection against harmful interference in a residential installation. This equipment generates uses and can radiate radio frequency energy and, if not installed and used in accordance with the instructions, may cause harmful interference to radio communications. However, there is no guarantee that interference will not occur in a

particular installation. If this equipment does cause harmful interference to radio or television reception, which can be determined by turning the equipment off and on, the user is encouraged to try to correct the interference by one or more of the following measures:

- Reorient or relocate the receiving antenna.
- Increase the separation between the equipment and receiver.
- Connect the equipment into an outlet on a circuit different from that to which the receiver is connected.
- Consult the dealer or an experienced radio/TV technician for help.

FCC Radiation Exposure statement

This equipment complies with FCC radiation exposure limits set forth for an uncontrolled environment. This equipment should be installed and operated with minimum distance 20cm between the radiator & your body.

ISED Statement

This device complies with Industry Canada licence-exempt RSS standard(s). Operation is subject to the following two conditions:
(1) this device may not cause interference, and

(2) this device must accept any interference, including interference that may cause undesired operation of the device.” This equipment should be installed and operated with a minimum distance of 20 cm between the radiator and your body.

Le présent appareil est conforme aux CNR d'Industrie Canada applicables aux appareils radio exempts de licence. L'exploitation est autorisée aux deux conditions suivantes :

(1) l'appareil ne doit pas produire de brouillage, et

(2) l'utilisateur de l'appareil doit accepter tout brouillage radioélectrique subi, même si le brouillage est susceptible d'en compromettre le fonctionnement.”

Cet équipement doit être installé et utilisé avec une distance minimale de 20 cm entre le radiateur et votre corps.

MODIFICATION: Any changes or modifications not expressly approved by the grantee of this device could void the user's authority to operate the device.

Toute modification non approuvée explicitement par le fournisseur de licence de l'appareil peut entraîner l'annulation du droit de l'utilisateur à utiliser l'appareil.

This Class B digital apparatus complies with Canadian ICES-003.
Cet appareil numérique de la classe B est conforme à la norme NMB-003 du Canada.

Operation of 5150-5350 MHz is restricted to indoor use only.
Le fonctionnement de 5150-5350 MHz est limité à une utilisation en intérieur uniquement.

Declaration of Conformity

RF exposure information: The Maximum Permissible Exposure (MPE) level has been calculated based on a distance of 20cm between the device and the human body. To maintain compliance with RF exposure requirement, use product that maintain a 20cm distance between the device and human body. Reolink declares that this device is in compliance with the essential requirements and other relevant provisions of Directive 2014/53/EU.

WiFi Operating Frequency

OPERATING FREQUENCY :
2402~2480MHz RF Power:≤10dBm(EIRP)
2412~2472MHz RF Power:≤20dBm(EIRP)
5150~5250MHz RF Power:≤23dBm(EIRP)
5250~5350MHz RF Power:≤23dBm(EIRP)
5470~5725MHz RF Power:≤23dBm(EIRP)
5725~5875MHz RF Power:≤14dBm(EIRP)



The functions of Wireless Access Systems including Radio Local Area Networks(WAS/RLANs) within the band 5150-5350 MHz for this device are restricted to indoor use only within all European Union countries (BE/BG/CZ/DK/DE/EE/IE/EL/ES/FR/HR/IT/CY/LV/LT/LU/HU/MT/NL/AT/PL/PT/RO/SI/SK/FI/SE/TR/N O/CH/IS/LI/UK(NI))



Correct Disposal of This Product

This marking indicates that this product should not be disposed with other household wastes throughout the EU. To prevent possible harm to the environment or human health from uncontrolled waste disposal, recycle it responsibly to promote the sustainable reuse of material resources. To return your used device, please use the return and collection systems or contact the retailer where the product was purchased. They can take this product for environmentally safe recycling.

Limited Warranty

This product comes with a 2-year limited warranty that is valid only if purchased from Reolink Official Store or a Reolink authorized reseller. Learn more: <https://reolink.com/warranty-and-return/>.
NOTE: We hope that you enjoy the new purchase. But if you are not satisfied with the product and plan to return, we strongly suggest that you reset the camera to factory default settings and take out the inserted SD card before returning.

Terms and Privacy

Use of the product is subject to your agreement to the Terms of Service and Privacy Policy at reolink.com

REOLINK INNOVATION LIMITED

FLAT/RM 705 7/F FA YUEN COMMERCIAL
BUILDING 75-77 FA YUEN STREET MONG KOK
KL HONG KONG

Terms of Service

By using the Product Software that is embedded on the Reolink product, you agree to the terms&conditions between you and Reolink. Learn more:
<https://reolink.com/terms-conditions/>

Technical Support

If you need any technical help, please visit our official support site and contact our support team before returning the products,
<https://support.reolink.com>.